

**INSTALLATION
INSTRUCTIONS**

Accessory

Application

Publications No.

**POWER ANTENNA
P/N 08B41-SR2-100****1997 DEL SOL****All 18040**

Issue Date

AUG 1996**PARTS LIST**

Power antenna

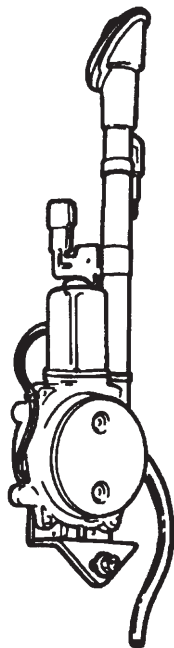

Power antenna harness

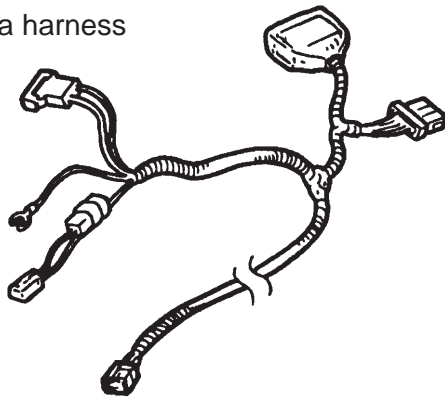

6 Cushion tapes



3 Wire ties

**TOOLS REQUIRED**

#2 Phillips screwdriver
10 mm Combination wrench
Ratchet
Antenna nut wrench
(T/N 07JAA-001000C)

INSTALLATION

Before You Begin:

- Write down the customer's radio station presets; the radio memory will be erased when you disconnect the battery.
- If the radio has a coded theft protection circuit, be sure you have the anti-theft code number before you disconnect the battery.

1. Disconnect the negative cable from the battery.
2. Remove the center console (five self-tapping screws, one connector).

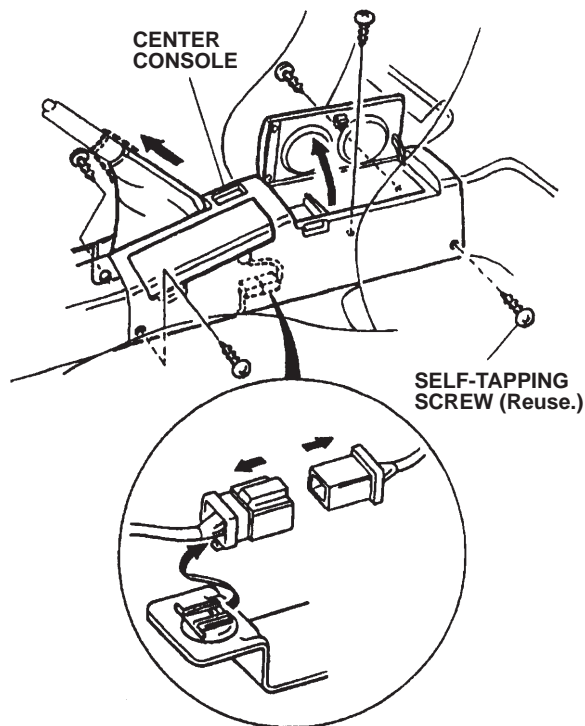

3. Inside the vehicle, remove the rear bulkhead cover (nine clips, pull gently).
4. Remove the rear storage compartment (six self-tapping screws, six clips).

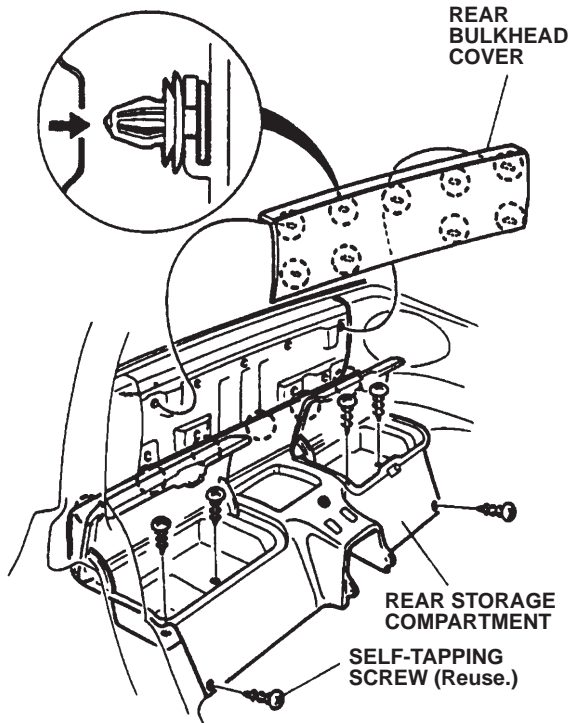

: Shows retaining clip.

5. Remove the right (passenger's side) upper and lower linings (four self-tapping screws, two expansion clips, two retaining clips). Take care not to damage the retaining clips.

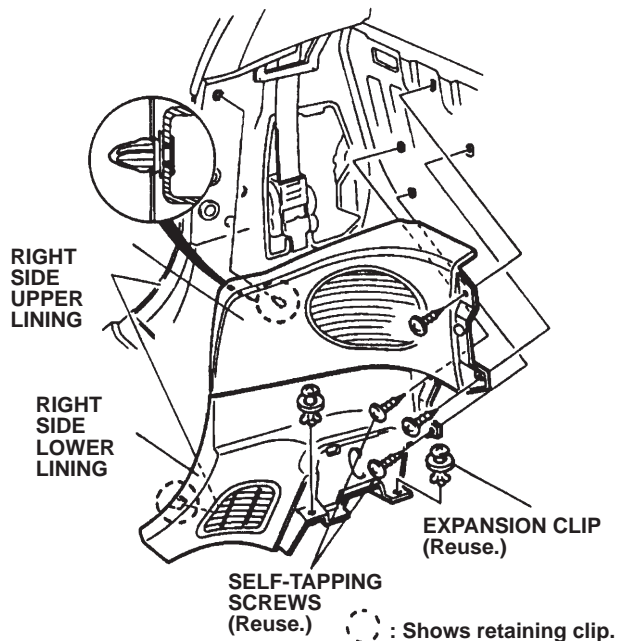

6. Remove the front console:
M/T only: two self-tapping screws, shift knob, two clips.

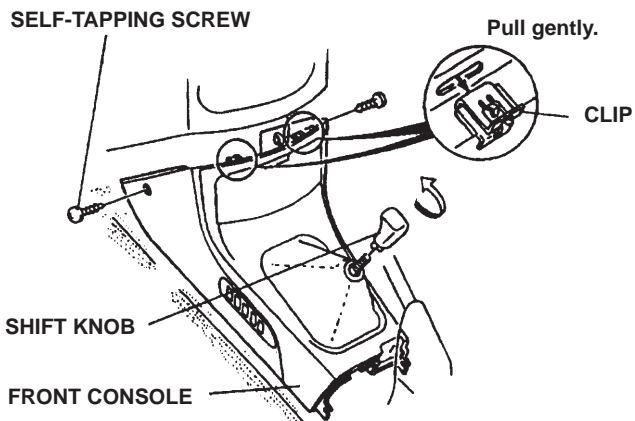

A/T only: two self-tapping screws, rubber trim ring, two clips.

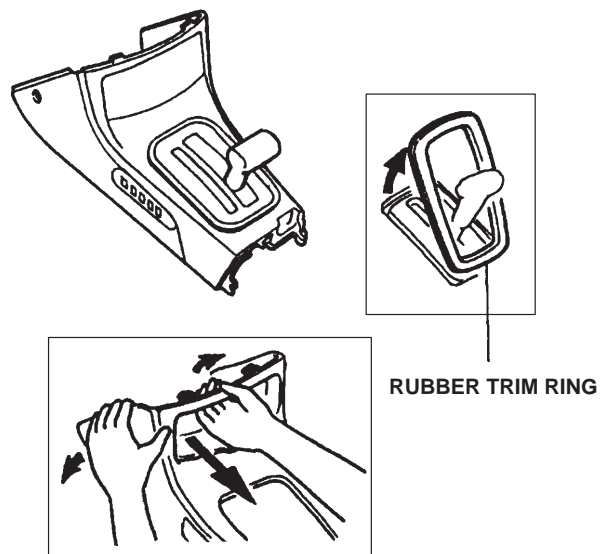

7. Remove the radio from the radio bracket. Refer to the Radio Installation Instructions furnished in the binder.

Routing the Power Antenna Harness

- Route the power antenna harness (the end with the ground terminal and 1-pin connector with fuse) over the steering shaft. Route the other end to the right (passenger's side) of the vehicle under the center frame.

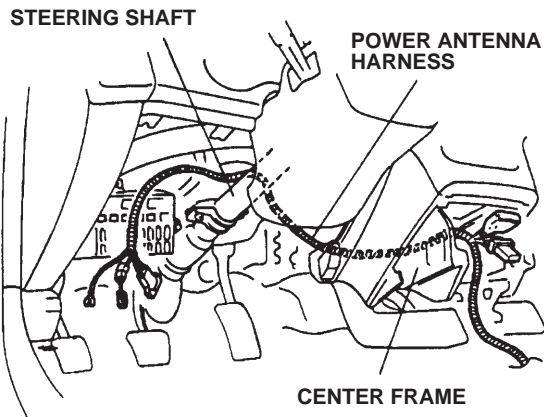

- Plug the 1-pin connector of the power antenna harness into the No. 5 connector of the fuse box. (The other 1-pin connector is used when installing the security system.) Loosen the bolt fastening the top of the hood opener lever, and install the ground terminal of the power antenna harness to this bolt; then tighten the bolt.

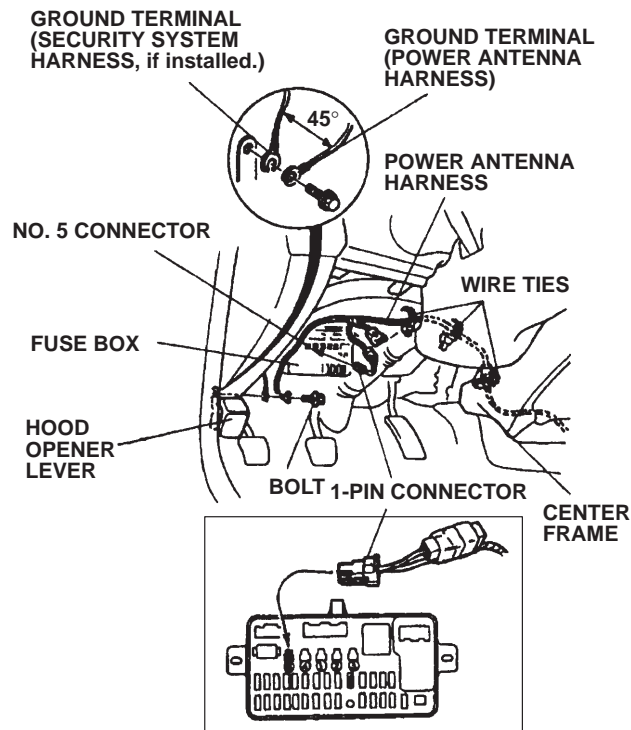

- Secure the power antenna harness to the vehicle harness and the center frame with the three wire ties in the areas shown. Check that the power antenna harness is not sagging or pulled tight. If necessary, reinstall the wire ties.

- Unplug the 16-pin connector from the rear of the radio, and connect the 16-pin connector of the power antenna harness in between.
- Reinstall the radio.

16-PIN CONNECTOR OF VEHICLE HARNESS

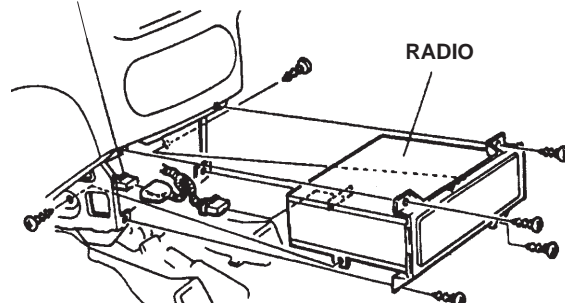

- Route the power antenna harness toward the rear under the floor carpet.
- Secure the power antenna harness to the floor with three cushion tapes.

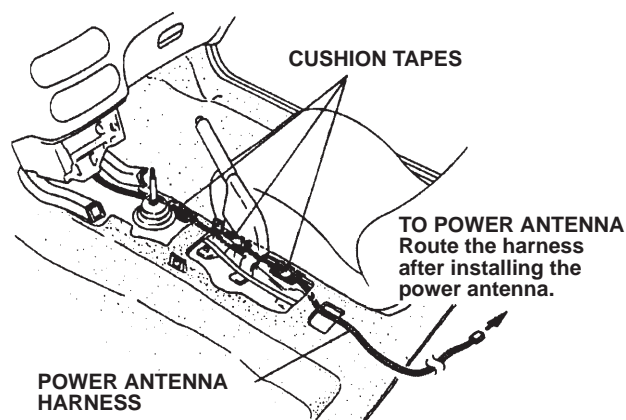

- Remove the tape to free the antenna lead.

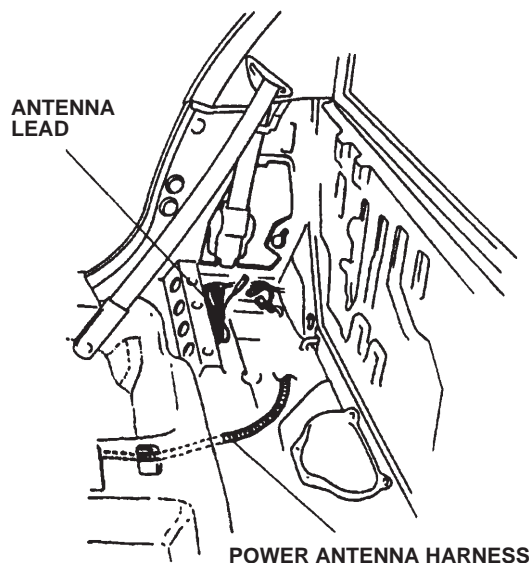

16. Remove the antenna cover (two screws).

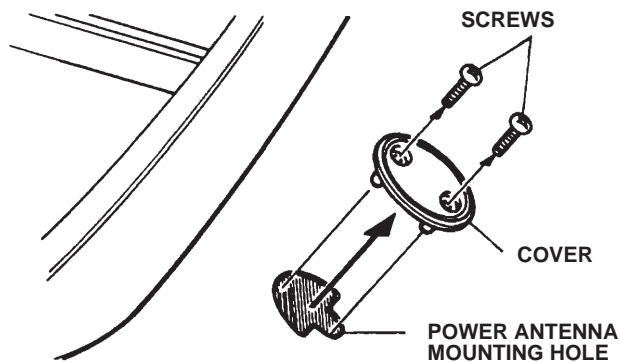

17. Remove the antenna nut and the guide base from the power antenna. Connect the antenna lead from the radio and the 3-pin connector of the power antenna harness to the power antenna.

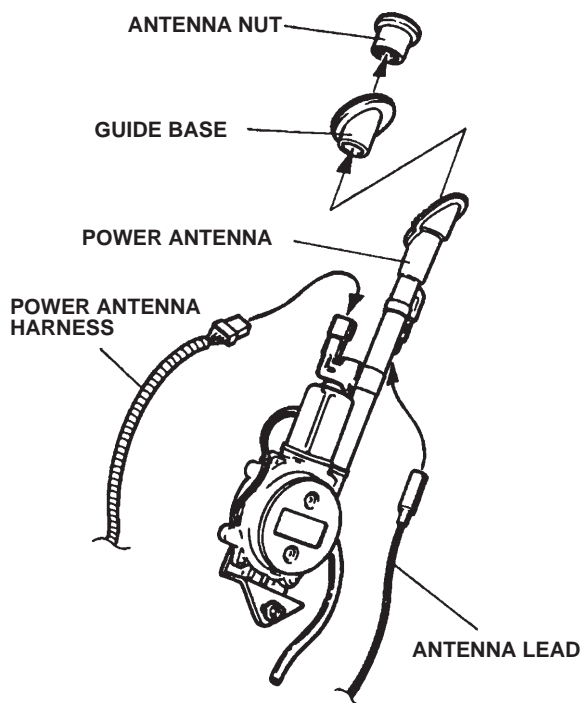

18. Set the power antenna into position with the stud on the antenna through the hole in the frame. Temporarily install a nut on the stud, and install the guide base and the antenna nut.

19. While pushing up on the power antenna, tighten the nut on the stud; then tighten the antenna nut using the special tool.

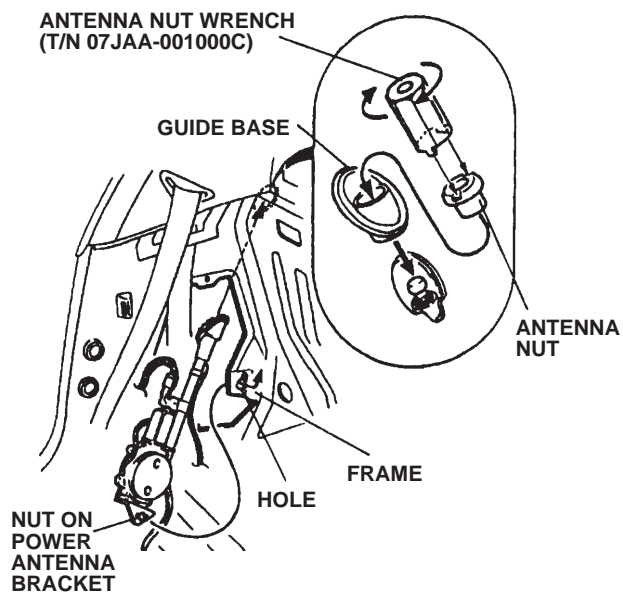

20. Secure the power antenna harness with three cushion tapes in the areas shown.

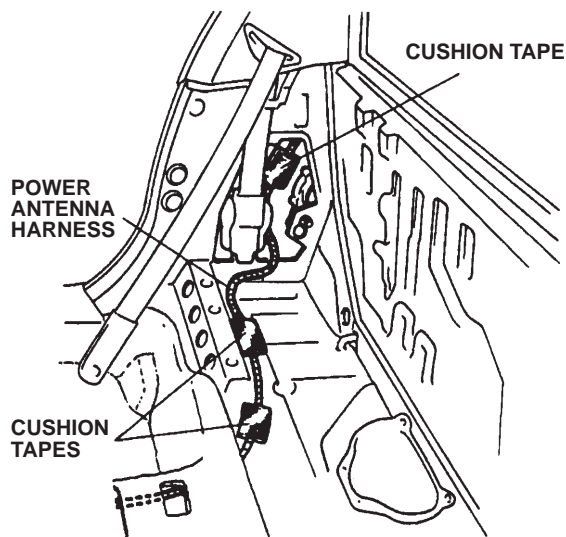

21. Check that all wire harnesses are plugged in and routed properly.
 22. Reinstall all removed parts.
 23. Reconnect the negative cable to the battery.
 24. Check the operation of the power antenna.
 25. Enter the customer's radio anti-theft code, if applicable, and reset the radio station presets.
 26. Reset the clock.